

THE FL-MIKRO WITH TOUCH PANEL



Menu

Site:	2	Technical Data
	3	1.0 Programing FL-MIKRO
	3	1.1 Menu guide
	4	1.2 Menu start
	4	1.2.1 Start via Touch-Panel "Hand Start"
	4	1.2.2 End-Signal via Touch-Panel program
	5	1.2.3 Program choosing via Touch-Panel „Hand-Program“
	5	1.3 Main menu
	5	1.3.1 Contrast setting
	6-7	1.4 Program data
	7	1.5 Calibration (for devices with interface)
	7	1.5.1 Automatic Calibration
	7-8	1.5.1.1 Entering calibration values / Activation of the calibration graph
	8	1.5.1.2 Assigning of the calibration graphs to a program / Numbers of the max. possible calibration graphs
	9	1.5.2 Calibration (for devices with contact actuation)
	9-10	1.5.2.1 Automatic Calibration / Entering calibration values / Activation of the calibration graph
	10	1.5.2.2 Classifying of the calibration graphs to a program / Numbers of the max. possible calibration graphs
	10	1.6 Check
	10	1.6.1 AD-Check
	11	1.6.2 Probe check
	11	1.6.3 Check of microwave moisture probe for device FL-MIKRO with a voltmeter
	12	1.7 Dose manual
	12	2.0 Fix Water Setting
	12	3.0 Clamp connection, program actuation via contact choosing, equipment diagram
	12	3.1 Clamp diagram FL-MIKRO / BUS-Card
	13	3.2 Installation diagram
	13	3.3 Clamp connection diagram / Generals
	13	3.4 Clamp connection diagram / Inputs
	14	3.5 Clamp connection diagram / Program connection
	14	3.6 Clamp connection diagram / Outputs
	14	3.7 Connection diagram of probe cable
	15	3.8 Output card FL-AT / 230VAC ; 115VAC ; 24VAC ; until max. 48VDC
	15	3.9 Output card FL-AT / 24VDC
	15	3.10 Arranging of cards and device fuses
	16-18	4.0 Selection of installation place on different mixer types
	19	4.2 Exchange of the wear and tear head
	19	4.3 Installation of water controls
	19	4.3.1 Water supply to the mixer (Drawing)
	20	4.3.2 Water distribution
	20	5.0 Error shooting / Failure announcement
	21-22	5.1 Error announcements of the FL-MIKRO and possible causes
	22	5.2 Checklist for water dosing plant
	23	5.3 Interference of ISM-Frequencies
	23	6.0 Serial Interface RS 232 (Optionally)
	23	6.1 Plug Connection

TECHNICAL DATA FL-MIKRO

The **FL-Mikro** consists of a computer, electronic evaluation boards, with a display unit and terminal and a microwave probe for installation in the mixer. The measurement is performed by microwave signals, from which the average value is created. The dosing takes place through a watercounter (the water quantity is displayed in litres or pounds).

Applications

Concrete Manufacturing Industries, Ceramic Manufacturing Industries, Glass Manufacturing Industries and Metal Foundry Industry.

Ports

Printer, RS 232, and optional Monitor

Model

slide in 19" rack; optional dustfree and spraywater protected slide in overhousing

Technical Data

Dimensions	483 mm (19" rack)
Weight	11 pounds
Power Supply	230V \pm 10% (110V \pm 10%) 50/60 Hz
Temperature	32°F to 160°F
Control Outputs	Current free (max. 0,8A) 230V AC or 48V DC
Measuring Signal Output	0 - 20 mA
Accuracy	\pm 0,5 L / 1 m ³
Control Inputs	Current free
Receipe Inputs	Decimal (40), BCD Code (100), or RS 232
Specifications of Watercounter	0,5 L = 1 impulse 1" or optional 1,5 - 2.0"
Error Messages	Display, Current free contact, acoustic and RS 232

Technical Data of the Microwave Probe

Diameter	74,5 mm
Length	90 mm / 172 mm / 420 mm
Weight	3,1 lbs / 5,2 lbs
Power Supply	24 V DC
Power Usage	Approx 10 VA
Temperature Range	32°F to 150° F
Measuring Signal Output	0 to 20 mA
Accuracy	Approx. + 0,3 RM (relative moisture)

1.0 Programing FL-MIKRO

1.1 Menu guide

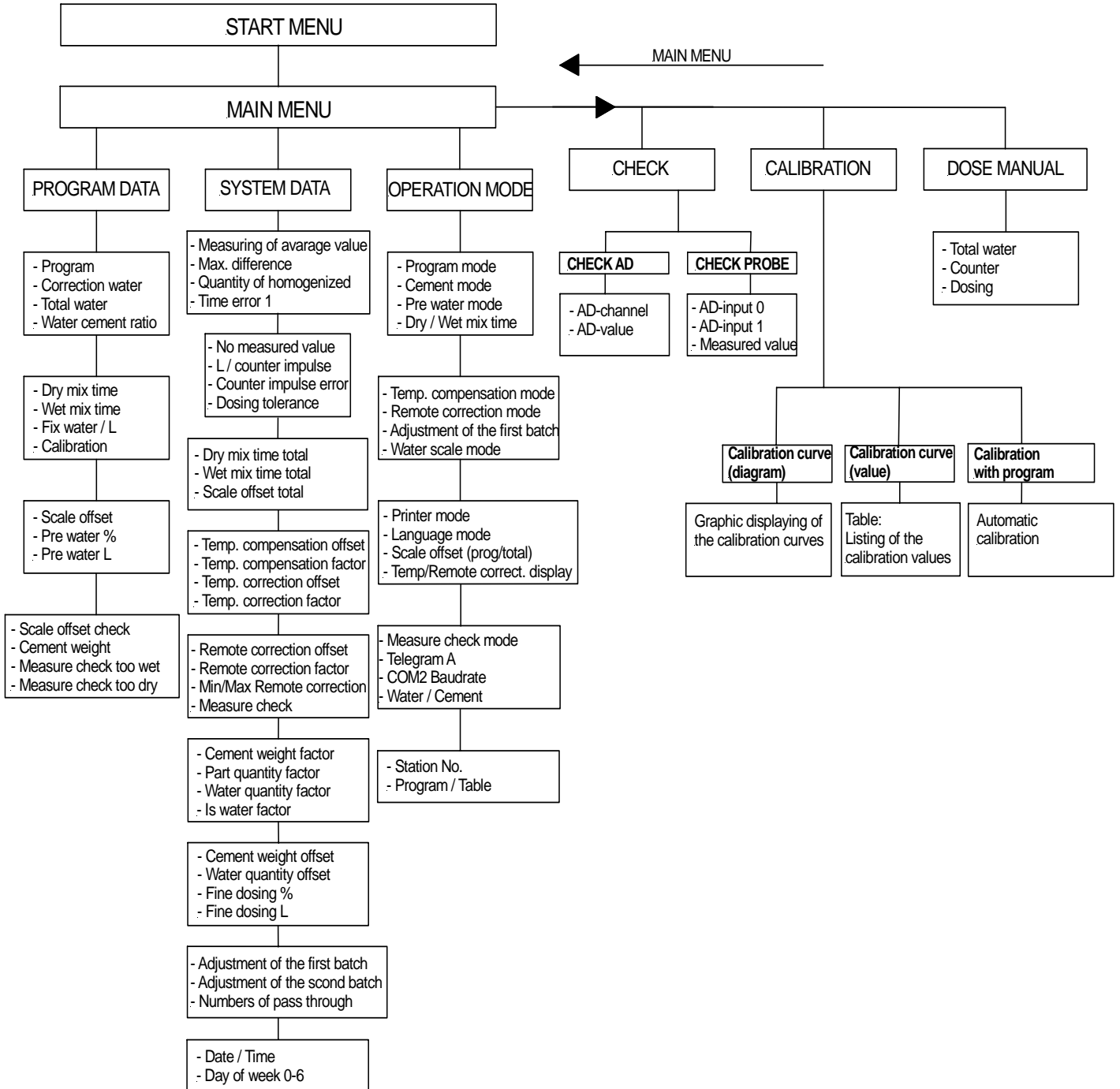

1.2 START MENU

After starting of FL-MIRKO the menu "START" appears on the touch-panel.

For "MAIN MENU" touch the ">". If you have an interface device you have to touch the RESET-key before the ">".

- 1 Shows the actual program.
- 2 Shows the program's cement weight resp. the weight given from the cement scale.
- 3 Shows the program's water/cement-ratio.
- 4 Informs about the last water quantity.
- 5 Informs about the last needed set-water.
- 6 Informs about the last dosed water quantity including any necessary later water flowment. Any water quantity additionally dosed over the menu "HAND-WATER" is even counted.
- 7 Actual measured moisture's value diagram on display.
- 8 Actual measured moisture's value diagram on display.
- 9 **Enter field:** - Entering of numeric letters 0 - 9

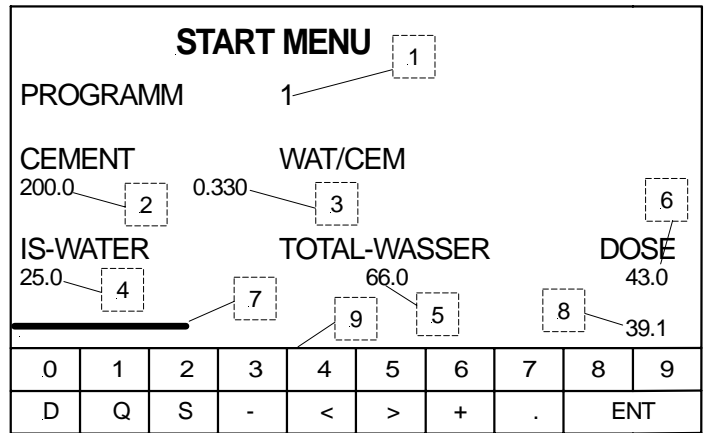

Function of following buttons:

- D** = Delete Key (without function in the start menu)
- Q** = Calling of "END"-Impulse
- S** = Start of chosen program
- = Reducing of WAT/CEM-Ratio (½ litre steps)
- <** = Relegating menu change
- >** = Ascending menu change
- +** = Raising of WAT/CEM-Ratio (½ litre steps)
- .** = (Without function in the start menu)
- ENT** = Confirmation key

1.2.1 STARTING WITH TOUCH-PANEL

START MANUAL:

The actual chosen program is started when touching "S"-key in the "START MENU".

Final confirmation of "START PROGRAM" when touching "YES".

Back to start menu when touching "NO".

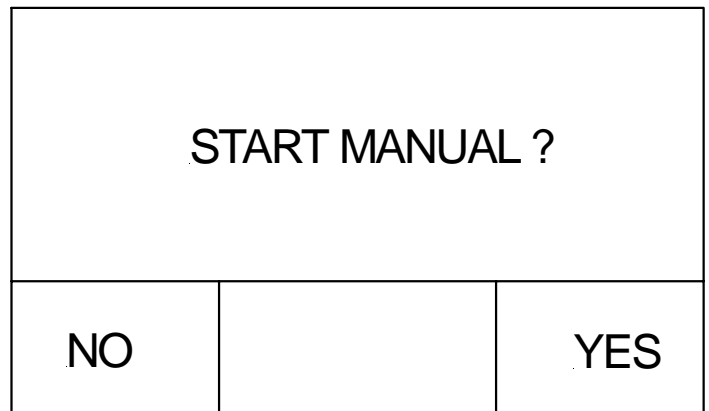

1.2.2 Program End Signal with Touch-Panel

SIGNAL MIXTIME END:

When confirmation with the "Q"-key in "START MENU", "MIXTIME END SIGNAL" is calling up:

For final confirmation of "MIXTIME END SIGNAL" please touch "YES".

Back to the "START MENU" when touching "NO".

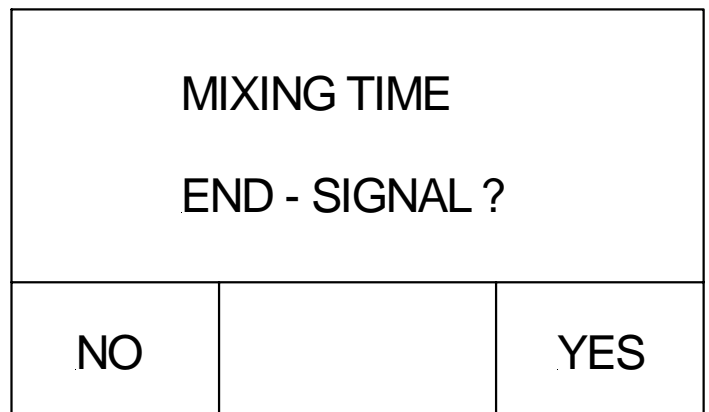

1.2.3 PROGRAM CHOOSING WITH TOUCH-PANEL

You can also choose programs in the "START MENU" with the Touch-Panel. (In condition if "MODE PROGRAM" = "0" is adjusted in the menu "MODE")

An external program choosing is not possible when using this mode.

To choose another program touch "ENT".

The cursor is flashing after "PROGRAM" and you can enter the desired program number with the keypad.

Confirm with "ENT" your input and start the program sequence with "S" or via start contact (clamp 26,27) .

The program is even fixed after the end of program resp. after a program interruption.

START MENU									
PROGRAM 1									
CEMENT		0.330		WAT/CEM					
IS-WATER			TOTAL-WASSER				DOSE		
25.0			66.0				43.0		
									39.1
0	1	2	3	4	5	6	7	8	9
D	Q	S	-	<	>	+	.	ENT	

1.3 MAIN MENU

With pressing ">"-key in "START MENU" you can go to the "MAIN MENU"

Each menu part is activated when touching.

- 1 Contents all program specific data.
- 2 Fixed system configuration.
- 3 Is fixing the mode of the water dosing computer.
- 4 Setting of the correct Measure Behaviour
- 5 Function test of the probes.
- 6 Allows manual dosing.

MAIN MENU									
PROGRAM DATA		1		CALIBRATION				4	
SYSTEM DATA		2		CHECK PROBE				5	
OPERATION MODE		3		DOSE MANUAL				6	
0	1	2	3	4	5	6	7	8	9
D	Q	S	-	<	>	+	.	ENT	

1.3.1 CONTRAST SETTING:

The contrast of the Touch-Panel can be changed in "Main Menu". The display is temperature-compensated. Although it can be necessary to re-adjust the contrast focus of the display in certain cases (e.g. extreme temperature variations).

Go as follows:

- Touch the "FL-Logo" or the word "Main Menu" on the upper edge.
- Then enter "0" with the keyboard.

It appears:

The figures in the middle of the screen are not important and can be any other. Touch now "+" or "-" as long as the requested contrast setting is reached. Touch now "Quit" to save the setting and to return to the "Main Menu".

Contrast Value		
05		
+	-	QUIT

1.4 PROGRAM DATA

With touching ">"-key in "PROGRAM" and than pressing "START MENU" you can go to the "PROGRAM". All alternations can be saved when pressing the "S"-key on the pages and you are return into the "START MENU". You can go to "MENU PROGRAM DATA" after touching ">"-key in "START MENU" and after pressing "PROGRAM DATA" in "MAIN MENU".

In the menu „PROGRAM“ the specific parameters for every product are committed.

- 1 For alternations, please enter the program number here.
Touch „PROGRAM“ and enter the requested program numbers on the touch panel, then set with „ENT“.
- 2 The “Correction Water” quantity allows to affect the water quantity to dose shortly. This water value is added to the pre-set set water quantity or it is subtracted, if this value is negative.
- 3 Here the desired set water quantity (litres) of the demanded cement consistency (set water = IS-water + added water) is contending. For alternating this parameter, the Wat/Cem Ratio (point 4) is actuated when entering „ENT“.
- 4 Shows the requested set moisture as Wat/Cem Ratio.
For alternating of this value the set moisture value (point 3) is actuated analogous.

PROGRAM	1	5							
CORRECTION WATER	2	10,0							
TOTAL WATER	3	66,0							
WAT/CEM RATIO	4	0,330							
0	1	2	3	4	5	6	7	8	9
D	Q	S	-	<	>	+	.	ENT	

- 1 Contents the program specific dry mix time.
- 2 Contents the program specific wet mix time.
- 3 Gives the possibility of setting a fix water value for this program (e.g. if a failure can not be solved immediately). For more information's please see “2.6 Fix Water Setting”.
- 4 The parameter “CALIBRATION” defines the measuring table of this program.

You have the possibility to enter table 1 - 12 (for free definition).

DRY MIX TIME	1	20							
WET MIX TIME	2	20							
FIX WATER /L (0=OFF)	3	0							
CALIBRATION	4	1							
0	1	2	3	4	5	6	7	8	9
D	Q	S	-	<	>	+	.	ENT	

- 1 Contents the program specific scale value, which affects the measured Is-Wat/Cem-Ratio. When entering e.g. 0,01, the measured IS-Wat/Cem-Ratio is raised to 0,01. When entering e.g. -0,02, the measured IS-Wat/Cem-Ratio is lowered to 0,02. Only active if the parameter “SCALE VALUE (PROG/TOTAL)” is set to “1” in the menu “MODE”. Standard scale value setting: “0,000”, no correction.
- 2 This parameter is only active, if the function “MODE FIRST-WATER” = 1 is set in the menu “MODE”. The approx. water quantity to dose is already grasped during the short pre measurement. You define here how much percent of this water quantity will be added during the pre dosing.
- 3 This parameter is only active, if the function “MODE FIRST-WATER” = 2 is set in the menu “MODE”. You define here a fixed water quantity which is added during the pre dosing.

For more information please see “2.2 Pre Water Dosing”

SCALE OFFSET	1	20							
PRE WATER %	2	20							
PRE WATER L	3	0							
0	1	2	3	4	5	6	7	8	9
D	Q	S	-	<	>	+	.	ENT	

- 1 If your device is equipped with the function "MEASURE CHECK" you can affect the IS-Wat/Cem-Ratio of the measure check with "SCALE OFFSET MEASURE CHECK". If you enter 0,01 e.g., the measured IS-Wat/Cem-Ratio is raised up to 0,01, if you enter -0,02 e.g., the IS-Wat/Cem-Ratio is lowered to 0,02.
- 2 Here you find the cement weight of the corresponding recipe. It is updated automatically at every mixing, if the cement weight is transmitted from the control to the FL-Mikro (serial interface, 0-10V output). If the cement weight is set manually, fillings or similar cement replacing aggregates have to be added as 1/3 to the cement quantity. (Devices with contact actuation have the correction water at this place and the cement weight is at the first site of the recipe data.)
- 3 "MEASURE CHECK TOO WET" = top limit value (in percent from SET Wat/Cem-Ratio), when the error message "ERROR 7 / CONCRETE TOO WET" is monitored.
- 4 "MEASURE CHECK TOO DRY" = lower limit value (in percent from SET Wat/Cem-Ratio), when water is dosed afterwards.

You will find more informations for activating and using of measure check in point "2.7 MEASURE CHECK".

SCALE OFFSET MEASURE CHECK	1	0,000
CEMENT WEIGHT CHECK	2	200,0
MEASURE CHECK TOO WET	3	110
MEASURE CHECK TOO DRY	4	90

0	1	2	3	4	5	6	7	8	9
D	Q	S	-	<	>	+	.	ENT	

1.5 CALIBRATION (for devices with serial interface actuation)

You reach the 'MENU CALIBRATION' when touching ">"-key in "START MENU" and than pressing "CALIBRATION" in "MAIN MENU". When touching the "S"-key in the pages you are saving all entered alternations and are returning to the "START MENU", when touching the "<"-key.

Generals: With the help of the Calibration Graph you have the possibility to adjust the FL-MIKRO to a realistic Wat/Cem-Ratio and to correct the measurings in a way that varyings of the addition goods moisture are detected correctly and adjusted optimally.

1.5.1 AUTOMATIC CALIBRATION

1.5.1.1 ENTERING CALIBRATION VALUES/ACTIVATION OF THE CALIBRATION GRAPH

Change with the ">"-key from 'START MENU' to 'MAIN MENU'. Touch there the point 'CALIBRATION'.

It appears:

- 1 Displaying of the graphic course of the calibration graphs. Enter e.g. "1", to be informed of the course of the graph 1.
- 2 You have the possibility to enter the several points of the graph manually or to change the points in "CALIBRATION CURVE (VALUES)".
- 3 The calibration gets started with "CALIBRATION VIA PROGRAM".

Notices before using:

If you want to establish the automatic calibration for very wet mixings (plastic concrete) or very coarse mixings (e.g. Liapor), please see point "1.7.1.2 Specific Usings with Calibration Graphs".

- 1 At this point please enter the additional water quantity, which gives the requested concrete consistency at the present additional goods moisture.
- 2 The dry and the wet mix times are pre-set for the calibration with 50 sec. You should not change these times.
- 3 In "CALIBRATION CURVE" you will fix the number which the evaluated graph should be stored at. There are 12 graphs (no. 1-12) to choose.

CALIBRATION									
CALIBRATION CURVE (GRAFIC)	1	1							
CALIBRATION CURVE (VALUES)	2	1							
CALIBRATION WITH PROGRAM	3								

0	1	2	3	4	5	6	7	8	9
D	Q	S	-	<	>	+	.	ENT	

TOTAL ADDITIONAL WATER	1	20
DRY MIX TIME	2	50
WET MIX TIME	2	50
CALIBRATION CURVE	3	1

0	1	2	3	4	5	6	7	8	9
D	Q	S	-	<	>	+	.	ENT	

After entering the graph number and confirmation with "ENT" you

Wasserdosiercomputer F1

will reach the following control screen:

The FL-Mikro waits now for the start telegram (Telegram A) from the control, to start the calibration. For this reason, you should start a complete dosing / mixing cycle of your batching plant. As Target Wat/Cem-Ratio enter a Target Wat/Cem Ratio that corresponds to your product or which has been evaluated from your laboratory assistant.
 (e.g. for paving: Total Wat/Cem-Ratio = 0,35).

As soon as the control sends the start telegram to the FL-Mikro, the dry mix time starts. The following program sequence depends to:

- a) if the FL-Mikro doses the additional water quantity via valve itself
- or
- b) if the FL-Mikro gives the requested additional water quantity via "Telegram B" to the control and the control doses the water.

CALIBRATION									
TELEGRAM A									
0	1	2	3	4	5	6	7	8	9
D	Q	S	-	<	>	+	.	ENT	

a) The FL-Mikro doses the additional water itself "MODE WATER SCALE" = 0,3 or 4

After the measurement the FL-Mikro gives the measured EXISTING water quantity and the additional water quantity via "Telegram B" to the control. Than the FL-Mikro is dosing the additional water quantity. At the end of the dosing the additional water quantity (incl. an eventually running water) is displayed:

Confirm with "YES" to **continue** the calibration.
 Now the wet mix time and the second measurement follows. The calibration graph is evaluated of both measure results and displayed. After you touched the diagram at one of it's parts, the graph can be stored with "YES" at the following query.
 (Remark for the control manufacturer: After saving the graph with "YES" the "Mixtime end"-signal is given at clamp 24/25.)

After the calibration the corresponding calibration graph has to be stored with parameter "CALIBRATION CURVE" (1-12). Graph 13 is the pre-set standard graph of the device.

ADDITIONAL WATER TOTAL		21.5
NO		YES

b) The FL-Mikro gives the requested additional water to the control. The control is dosing the additional water. "MODE WATER SCALE" = 1

After the measurement the FL-Mikro gives the measured EXISTING water quantity and the additional water quantity via "Telegram B" to the control. The control doses the requested additional water quantity. It appears in the display:
 Only when the control has dosed the water **totally**, confirm with "YES". The wet mix time and the second measurement are following. The calibration graph is evaluated of both measure results and displayed. After you touched the diagram at one of it's parts, the graph can be stored with "YES" at the following query.
 (Remark for the control manufacturer: After saving the graph with "YES" the "Mixtime end"-signal is given at clamp 24/25.)
After the calibration the corresponding calibration graph has to be stored with parameter "CALIBRATION CURVE" (1-12). Graph 13 is the pre-set standard graph of the device.

1.5.1.2 ASSIGNING THE CALIBRATION GRAPHS TO A PROGRAM / NUMBERS OF MAX. POSSIBLE CALIBRATION GRAPHS

Assign the calibration graph to the corresponding program in "PROGRAM DATA". You can find the parameter "CALIBRATION GRAPHS" on the 2nd page in "PROGRAM DATA". It is very useful to do programs with the same additional aggregates compound and with a similar additional aggregates structure with the same calibration graph. It is necessary to take several measure graphs for all programs with have a very different compound of additional goods (coarse, fine) or structure (sand, LIAPOR, lava,...).You can take 12 calibration graphs maximum.
 If you fill all calibration graph values with "0" and then choose this calibration graph or calibration graph 13 in "Program Data", you are working with the device's internal standard calibration graph automatically.

1.5.2 CALIBRATION (for devices with contact actuation)

Generals: With the help of the Calibration Graph you have the possibility to adjust the FL-MIKRO to a realistic Wat/Cem-Ratio and to correct the measurings in a way that varyings of the addition goods moisture are detected correctly and adjusted optimally.

1.5.2.1 AUTOMATIC CALIBRATION / ENTERING CALIBRATION VALUES/ACTIVATION OF THE CALIBRATION GRAPH

Change with ">"-key from "START MENU" to "MAIN MENU".
 Tap "CALIBRATION" in you will reach the "CALIBRATION MENU". It appears:

Tap now "CALIBRATION VIA PROGRAM".
 The cursor stats flashing.

Enter now the program the calibration should be done with.

Example:

Touch program no. "1" and confirm with "ENT".
 The following screen appears:

CALIBRATION									
CALIBRATION CURVE (GRAFIC) 1 — 1									
CALIBRATION CURVE (VALUES) 2 — 1									
CALIBRATION WITH PROGRAM 3 — 5									
0	1	2	3	4	5	6	7	8	9
D	Q	S	-	<	>	+	.	ENT	

The dry and wet mix times are set standardly to 50 sec. to guarantee a sufficient mixing and an optimal calibration. These pre-given times should be kept. If required, they can be changed: Enter the present cement weight of the mixing in the mixer at "Cement Weight".

Press now "ENT".

Before, please pay attention:

When the automatic calibration should be proceeded for very wet mixings (plastic concrete) or very coarse minxings (e.g. Liapor), pay attention to point: 1.7.2.2. SPECIFIC USING WITH CALIBRATION GRAPHS.

CALIBRATION									
DRY MIX TIME									50
WET MIX TIME									50
CEMENT WEIGHT									200
0	1	2	3	4	5	6	7	8	9
D	Q	S	-	<	>	+	.	ENT	

It appears:

- 1** The requested Wat/Cem-Ratio can be chosen through touching the parameter „SET W/C-RATIO“ (The pre-given Wat/Cem-Ratio for this program is present initially).
- 2** Touch now "Additional Water Total".
 The cursor starts flashing.
 Enter now the water quantity to dose for this program.
 Confirm with "ENT".
- 3** In "START CALIBRATION" you are able to set the number at which the evaluated graph should be stored. There are 12 graphs (no. 1-12) to choose.

Before proceeding forward with the calibration, point 3 has to be finished.

SET WAT/CEM 1 — 0,35									
ADDITIONAL WATER TOTAL 2 — 20									
START CALIBRATION 3 — 1									
0	1	2	3	4	5	6	7	8	9
D	Q	S	-	<	>	+	.	ENT	

This display is for controlling the entered parameters.
 Tap 'NO' and you return to the calibration menu (see point 1.7.2.1).
 Tap 'YES' and the automatic calibration starts.

- The calibration is proceeded as follows:
- Dry Mix Time
 - Measurement
 - Dosing
 - After the dosing the additional water quantity is displayed. Confirm with 'YES'.
 - Wet Mix Time
 - 2nd Measurement

After the 2nd Measurement the calculated calibration graph is displayed.

When touching the display a query appears for saving this calibration graph. You have to answer with 'YES' or 'NO'.

START CALIBRATION		
CALIBRATION CURVE		1
PROGRAM		5
SET WAT/CEM		0.350
ADDITIONAL WATER TOTAL		20,0
NO		YES

After the calibration the corresponding calibration graph has to be stored with parameter "CALIBRATION CURVE" (1-12).

1.5.2.2 CLASSIFYING OF THE CALIBRATION GRAPHS TO A PROGRAM /NUMBRES OF THE MAX. POSSIBLE CALIBRATION GRAPHS

Fix the calibration graph to the corresponding programs in "PROGRAM DATA". You can find the parameter "CALIBRATION GRAPHS" on the 2nd page in "PROGRAM DATA". It is very useful, to do programs with the same additional aggregates compound and with a similiar additional aggregates structure with the same calibration graph. it is necessary to take several measure graphs for all programs with have a very different compound of additional goods (coarse, fine) or structure (sand, LIAPOR, lava,...). You can take 12 calibration graphs maximum. If you fill all calibration graph values with "0" and then choose this calibration graph or calibration graph 13 in "Program Data", you are working with the device's internal standard calibration graph automatically.

1.6 CHECK

You can go to the menu "CHECK" after touching the ">"-key in "START MENU" and after pressing "CHECK" in "MAIN MENU".
 When touching "S"-key on the several pages you are going back to "START MENU".

Generals: In the menu "CHECK" you have the possibility of monitoring the 8 anaologous inputs of the FL-MIKRO.

- 1 With "AD-TEST" you have the possibility of monitoring the 8 analogous inputs (channel 0 untill channel 7) of the FL-MIKRO. The analogous input sizes are changed into digital values (0-4095) The channels 0-4 are reserved for the microwave probe (0,1), the cement weight reading (2), remote correction (3) and temperature compensation (4). You will find advices for evaluation of the particular digital values in "AD-TEST" in the depending chapters of the manual.
- 2 With "PROBE TEST" you have the possibility to check the microwave probe and the probe mains cable perfect function.

CHECK										
0	1	2	3	4	5	6	7	8	9	
D	Q	S	-	<	>	+	.	ENT		

1.6.1 AD-CHECK

- 1 Channel monitoring.
- 2 Digital value of the chosen analogous input. Touch „AD-CHANNEL" (curser starts flashing) and enter the desired channel number with the keypad. After you confirmed with „ENT" the digital value (0-4095) of the particular input size is monitored.

AD-CHECK										
0	1	2	3	4	5	6	7	8	9	
D	Q	S	-	<	>	+	.	ENT		

1.6.2 PROBE CHECK

- 1 Digital displaying of both measuring channels of the probe.
- 2 Shows the measured value (Wat/Cem-Ratio) from the combined probe channels.
- 3 Grafic displaying of the measured moisture.
- 4 Specification of the bar graph as percent value.

Specification of the bar graph as percent value.

- 1 First clean the probe's surface and check that no water is able to gather on the probe.
- 2 Note the values of AD-channel 0 and AD-channel 1.
- 3 One person is pressing his palm firmly to the probe's measuring surface.
- 4 Note again the values of AD-channel 0 and AD-channel 1.

You will get these values (for ex.):

	PROBE FREE	PROBE COVERED
AD-VALUE 0	2267	2613
AD-VALUE 1	3979	388
MEASURED VALUE	0,000	0,489

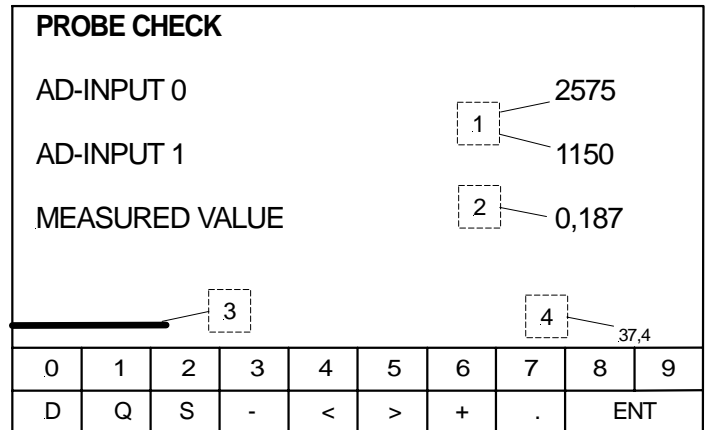

(Note: These values are only for illustration. The values of your probe can vary.)

- Both AD-values **have to range** between 0 (min) and 4095 (max.)
- AD-value 1 has to vary more than Ad-value 0 after covering with the palm.
- The measured value should be low when the probe is dry and not covered (ideal: 0.000)
- When the probe is covered, the measured value has to raise to 0,3.

One or both AD-values = 0

- Check if there are no cracks or damages on the probe's surface.
- Check the probe's current supply (clamp 52 = +24 V, clamp 53 = GND 24 V)

When current supply is too low or missing, than the card FL-NT is probably damaged.

- Check all clamp- and plug connections of the probe cable.
- Check if the probe's cable is damaged or broken.

One or both AD-values = 4095

- Check if there are no cracks nor damages on the probe's surface.
- Check the probe cable for damages.

If the fault's cause is not clear, please contact one of our technicians for further action.

1.6.3 CHECK OF MICROWAVE MOISTUREPROBE FOR DEVICE FL-MIKRO-DUO WITH A VOLTMETER

- 1 Check the currency between clamp 52.1 (+24V) and clamp 53.1 (GND 24V) with a voltmeter that measures ranges over 20V DC. If you will not receive a result of 24V (tolerance $\pm 10\%$), the 24V power supply is defective.
Than go for the following steps:
- 2 Check the currency between clamp 16 (Channel 0) and clamp 14 (GND Meas.) and note it's result. You should receive approx. 5V. This value is independent from the status' of the probe (free or covered).
- 3 Check the currency between clamp 39 (Channel 1) and clamp 14 (GND Meas.) and note it's result. Measured currencies as follows: if the probe is covered: 1V, if the probe is free: approx. 7V up to 10V.
- 4 Loose the core of clamp 16 (Channel 0) and measure the currency between this core and clamp 14 (GND Meas.). Independent from the status of the probe (covered or free) a value of approx. 19V is appearing. Than fix the core to clamp 16 (Channel 0) again.
- 5 Loose the core of clamp 39 (Channel 1) and measure the currency between this core and clamp 14 (GND Meas.). You should receive a result of 19V, if the probe is free and of approx. 21V, if the probe is covered. Than fix the core to clamp 39 (Channel 1) again.
- 6 If you should not receive the given measured values of the above mentioned points 2-5, the probe is defective. If you received the above mentioned values, the connection from the probe to the controller unit, resp. the controller unit FL-Mikro DUO itself has to be checked.

1.7 DOSE MANUAL

You are going to "DOSE MANUAL" after touching the ">"-key in "START MENU" and after pressing "DOSE MANUAL" in "MAIN MENU". When touching the "S"-key you go back to the "START MENU". Change with „>“ from „START MENU“ to „MAIN MENU“. When touching "DOSE MANUAL" the program calls up. With the function "DOSE MANUAL" the user has the possibility to dose a former chosen water quantity in the mixer. This process can be repeated just often as the user wants. This function is only possible to choose, if valve and water counter are connected directly to the FL-MIKRO.

- 1 The desired water quantity can be entered when touching the parameter "TOTAL WATER". When entering "ENT" this water value will be taken over in the program.
- 2 "COUNTER" shows, how many water is flowing through the water counter. "COUNTER" is counting the former chosen quantity up to the set value.
- 3 "DOSING" shows the water value which is used while latest mixing. This parameter rises after hand dosing up to the water value which is already dosed.

Start through when touching „DOSING“.
 It appears:

With „YES“ the dosing starts. With „NO“ you go back to the menu „MANUAL WATER“.

MANUAL WATER									
TOTAL WATER	1								20.0
COUNTER	2								20.0
DOSING	3								75.0
0	1	2	3	4	5	6	7	8	9
D	Q	S	-	<	>	+	.	ENT	

DOSING ?		
NO		YES

2.0 FIX WATER SETTING

If failures of the FL-Mikro can not be solved immediately (e.g. via phone), you have the possibility to pre set a fix water quantity for each program in "PROGRAM DATA", which is additionally dosed when using this program.

Setting: In "PROGRAM DATA" at the 2nd page, point "Fix Water/L". If this parameter is set to "0", the FL-MIKRO works as a measure and dosing device. With any other settings the device works with fix water without measurement.

Part Charges: If the FL-MIKRO gets the program data via serial interface (in case of questions, please contact the Ludwig Company or your control manufacturer) or the concrete weight is read via analogue input (Menu "OPERATION MODE"; "CEMENT MODE" = 1 or 2), the FL-MIKRO is able to calculate part charges. The fix water quantity can be adjusted to the part charges automatically. Please enter the cement weight for a 100% mixing and the fix water quantity for a 100% mixing in the depending programs in "PROGRAM DATA". The part charges calculation is adapted automatically during the program sequence.

3.0 CLAMP CONNECTION

3.1 CLAMP DIAGRAM FL-MIKRO

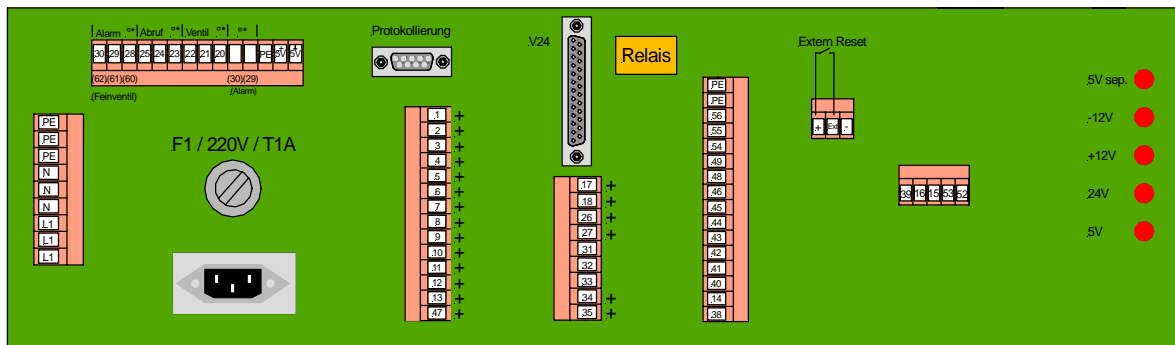

- + Potential free contacts from the control
- ° Potential free contacts from the FL-Mikro
- * Pay attention to the connecting of the connection of the FLAT-card (see pages 3.12 and 3.13)

3.2 INSTALLATIONSPLAN

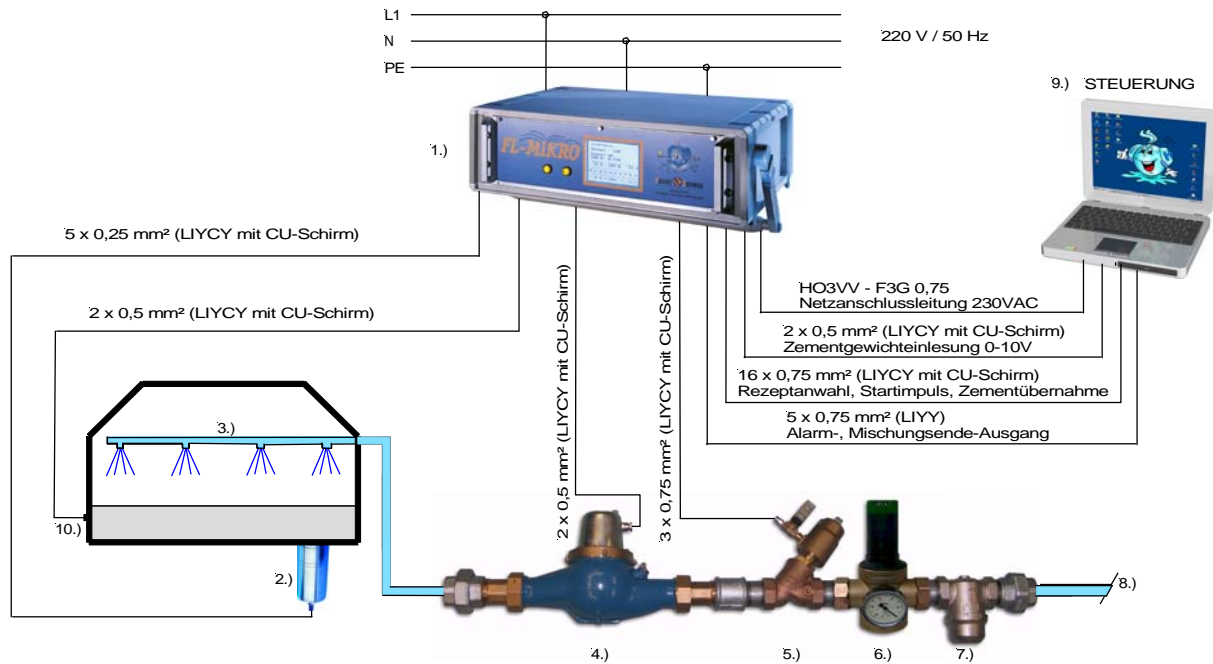

1. Water dosing computer FL-Mikro
2. Microwave moisture probe (choose able ground or wall installation)
3. Mixer
4. Water volume recorder
5. Magnetic valve
6. Pressure minimizer
7. Mudguard
8. Water pipe
9. Your control (depending to your actuation method the number of the electrical cables are different)
10. Temperature probe

3.3 CLAMP CONNECTION DIAGRAM / GENERALS

TO BE NOTICED ABSOLUTELY!

The water volume recorder, the program connection, the start impulse as well as the reading impulse (cement weight reading, temperature reading) have to be given from the control as potential free contacts.

The probe cable of the microwave probe and the signal cables for water volume recorder, cement weight, temperature probe and Remote correction has to be shielded. The shield has to be connected to the FL-Mikro.

3.4 CLAMP CONNECTION DIAGRAM / INPUTS: START, WATER VOLUME RECORDER

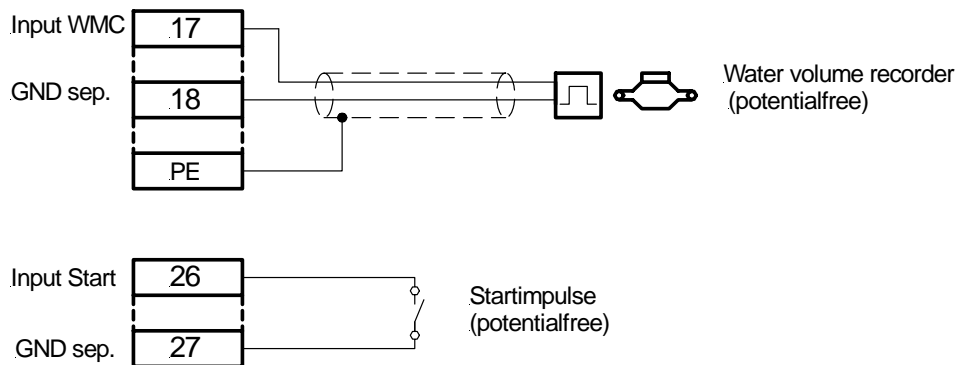

3.5 CLAMP DIAGRAM / PROGRAMCONNECTIN

The program connection has to be made via potential free contacts.

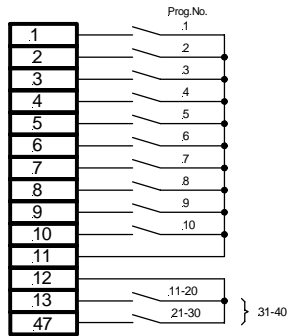

0-40 programs (decimal)

Program Mode = 2

Combination examples:

If clamps 13 and 47 are connected with clamp 12 and additionally clamp 5 is connected with clamp 11 via switch contacts, program 35 is chosen.

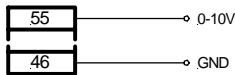

0-40 programs via analog inputs (0-10V)

(Mode program = 1)

Clamp 55 is only optional and is prepared if desired before the device is delivered.

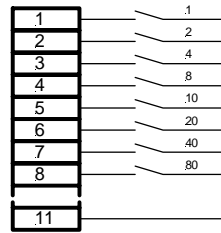

0 - 150 programs (BCD-coded)

Program Mode = 3

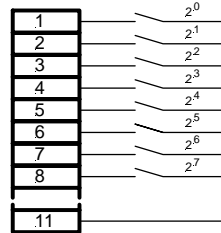

0 - 200 programs (binary-coded)

Program Mode = 4

3.6 CLAMP DIAGRAMM / OUTPUTS VALVE, END SIGNAL, ALARM

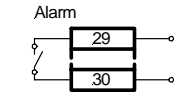
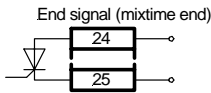
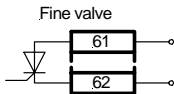
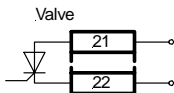

Standard description
(24V- up to 220V-)

The outputs valve, fine valve and the end signal given as potentialfree Triacoutputs from FL-Mikro.
The alarm output is given as potentialfree relais output. Please notice even sheet 3.11 concerning the equipment of the FLAT card.

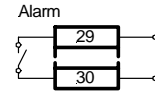
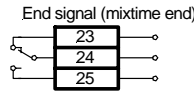
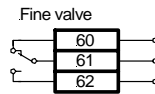
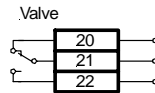

Relais connection
(up to max. 48V=)

The outputs valve, fine valve and end signal and alarm are given from the FL-Mikro as potentialfree relais outputs. Please notice even sheet 3.12 concerning the equipment of the FLAT card.

3.7 CONNECTION DIAGRAMM OF PROBE CABLE

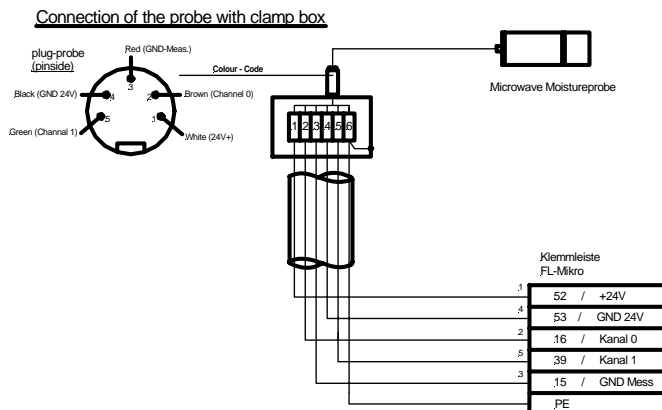

BITTE BEACHTEN:
Mischer und Standort des Gerätes müssen durch ausreichenden Potentialausgleich (z.B. Potentialausgleichsleitung > 8mm²) miteinander verbunden sein.

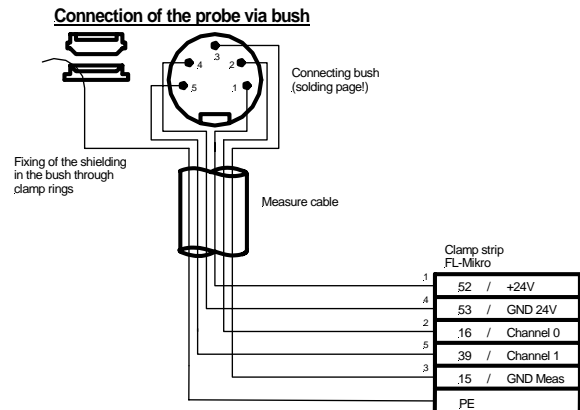

IMPORTANT:
Mixer and device Location have to be connected together through an sufficient potential equalization (e.g. potential equalization cable > 8mm²)

**3.8 OUTPUT CARD FL-AT
 (230 VAC ; 115 VAC ; 24 VAC ; UNTILL MAX. 48 VDC)**

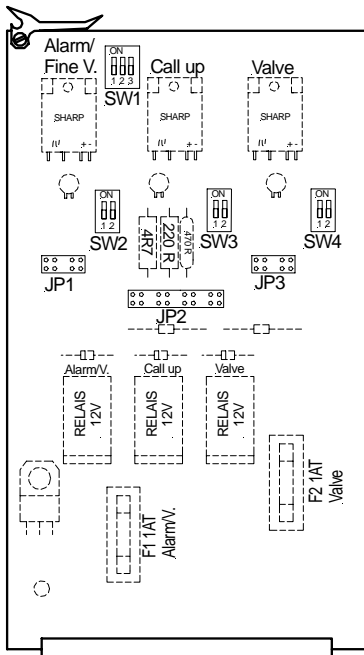

- Valve untill max. 48 VDC:**
 SW 1/3 = off
 SW 4/1 = on und SW 4/2 = off
 JP3
- Valve 24 - 230 VAC:**
 SW 4/1 = off und SW 4/2 = on
 SW 1/3 = on
 JP3
- Call up untill max. 48 VDC:**
 SW 3/1 = on und SW 3/2 = off
 SW 1/2 = off
 JP2
- Call up 24 - 230 VAC:**
 SW 3/1 = off und SW 3/2 = on
 SW 1/2 = on
 JP2 24 VAC
 JP2 115 VAC
 JP2 230 VAC
- Alarm/Fine Valve untill max.48 VDC:**
 SW 2/1 = on und SW 2/2 =off
 SW 1/1 = off
 JP1
- Alarm/Fine Valve 24 - 230 VAC:**
 SW 2/1 = off und SW 2/2 = on
 SW 1/1 = on
 JP1

**3.9 OUTPUT CARD FL-AT
 (24 DC)V**

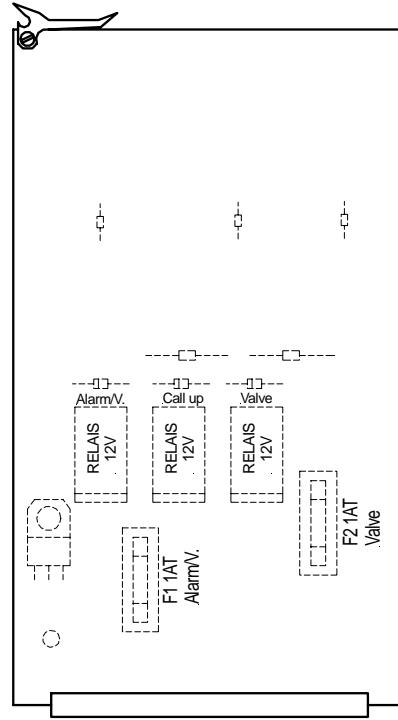

3.10 ARRANGING OF CARDS AND DEVICE FUSES

View when talking away the front plate

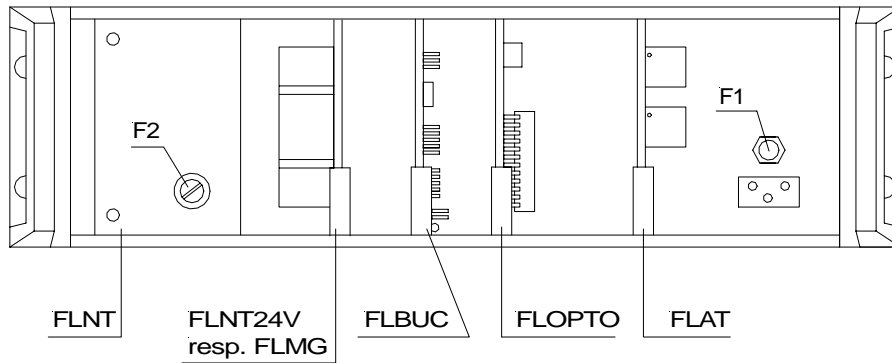

- FL-NT = Mains part
- FLNT 24V = Mains part 24 V (Microwave Measurement / FL-Mikro)
- FL-MG = Measure card (resistant / FL-W/Z)
- FLBUC = Computer card
- FLOPTO = Opto coupler card
- FLAT = Output card
- F1 = T 1A (when mains voltage 220V) / T 1,25A (when 110V)
 (Fuse is accessible from back of device)
- F2 = T 0,5A (when mains voltage 220V) / T 1A (when 110V)

Back of device

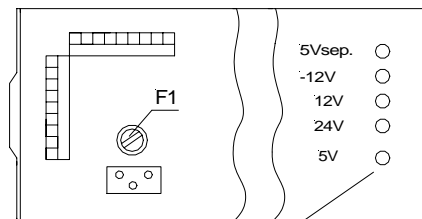

Control lights
 for the several
 used voltages

4.0 SELECTION OF INSTALLATION PLACE ON DIFFERENT MIXER TYPES

Only one microwave moisture probe is needed, independent from mixer type and size. To guarantee optimal measure results, the probe has not to be covered by material anytime and the material to measure has to be sufficiently homogenized.

INSTALLATION IN THE MIXER BOTTOM OF PLANETARY / ANNULAR PAN MIXERS

- Choose an installation place which is cleaned sufficiently overtimes (e.g. on the highest point of uneven mixer bottoms.).



Specific: Annular Pan Mixers

- If the mixer arms are giving during the dry mix process an insufficient homogenizing is according on the mixer bottom zone which results in error measurements.
- Remedy: Reduce the mixing size or re-adjusting the feathers.

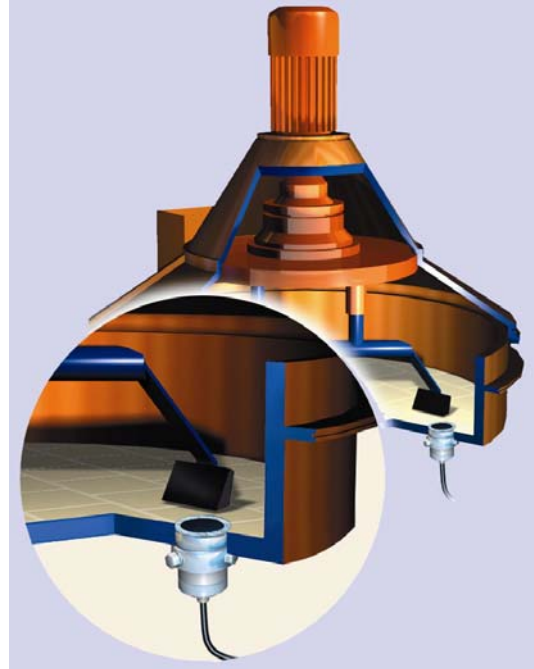

INSTALLATION IN INTENSIVE MIXERS

- The probe is installed in the bottom/wall-scraper with integrated holder.
- The probe's measure surface has to be installed at the same level as the scraper's.
- When producing very fine material it probably will be necessary to clean the probe through spraying after mixer emptying.
- The probe can even be installed in a separate holder arm.

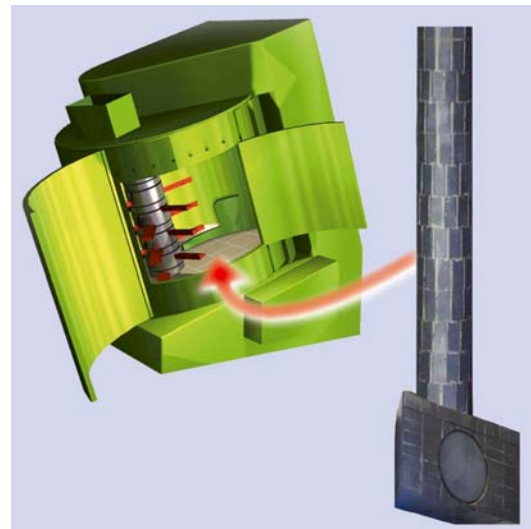

**INSTALLATION IN AN S
(SINGLE / DOUBLE)
SHAFT -MIXERS**

- We recommend the installation of our wear tile round.
- The probe should be installed in a middle distance between both side walls of the mixer pan.
(Approx. 1m distance to the side wall)
Best place: near the opening clap
- The probe should be installed at 05:00 approx.
(The mixer shares should transport the material upwards on the probe.)
- The above mentioned recommending is even to be considered with single shaft mixers.

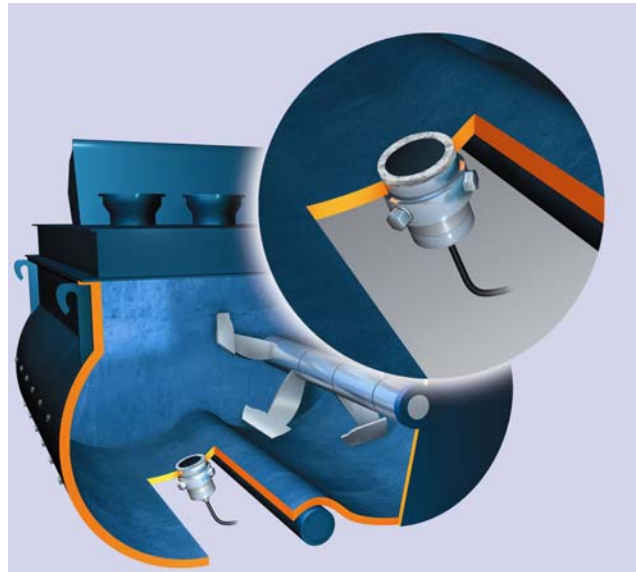

USEFUL TIPS

- The **probe** has to be installed in min. **1 meter** distance to **electric motors (p.E. mixer drive)**.
- The **probe** should be installed near an inspection clap.
- If the mixer bottom is **unevenly** used, the probe should be installed on the **highest** place of the bottom.
- The **holder surface and the probe's surface** have to be installed the same level as the **mixer bottom**.
- The distance of the probe's measure surface (centre) should take 15 cm from the inner side of the outer mixer wall minimum.
- The **probe cable** has not to be layed together with load carrying cables.
- **Before** installing in the holder, the **probe** should be lubricated with high-performance grease.
- Only **deinstalling** without using massive **force**. Pull out the **probe** of the holder only from bottom to top.
- **Welding working** in the probe's environment only with uninstalled probe.

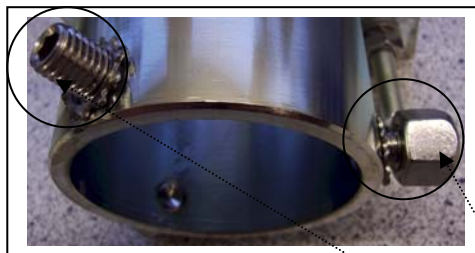

Please pay attention that all holder systems of Franz Ludwig GmbH are using hexagon socketed head cap screws. These screws are secured and protected additionally with conventional hexagon domed cap nuts.

HOLDER SYSTEMS

To protect the probe optimally against wear and electrical interference effects, one of the following holder systems has to be used:

Wear Tile ROUND

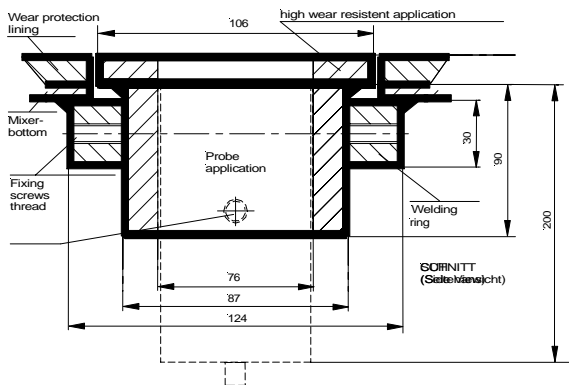

TOP VIEW

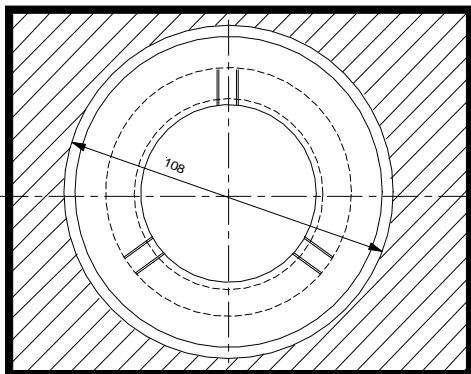

Wear Tile SQUARE

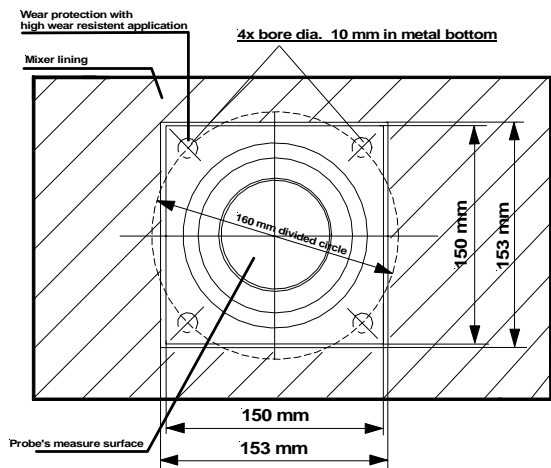
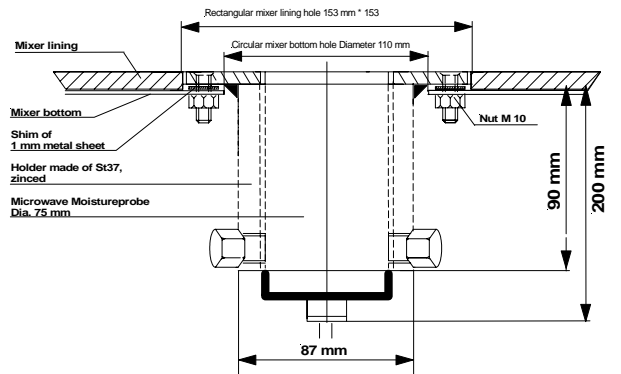

4.2 EXCHANGE OF THE WEAR AND TEAR HEAD

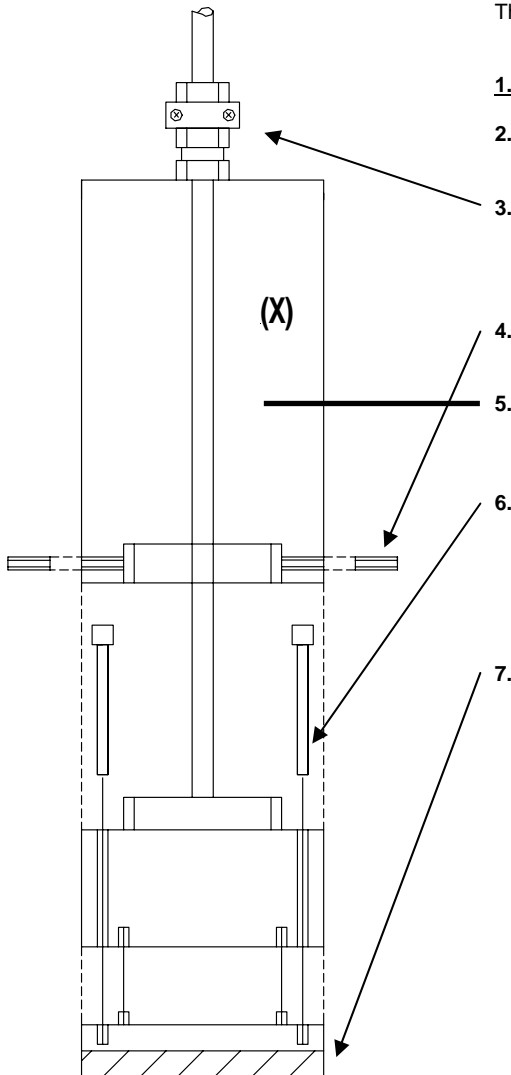

The lengthening of the probe **(X)** is only optionally,

1. Device has to be switched off !!!
2. Disconnect the probe plug resp. disconnect the probe from the clamp connection box.
3. Unscrew the cable relief.
4. Loosen inner hexagon screws.
5. Unscrew the lengthening (**Attention:** Turn only the lengthening for non-damaging the cable!)
6. Loosen the non sealed cylinder screws (4 Pcs.).
7. Take away the wear and tear head.

Put on the new wear and tear head cautiously, without tilting. You have to pay attention that the fixing pins of the wear and tear head fit the existent holes exactly.

When fixing, please use new cylinder screws and fix them tightly to avoid water damage of the inner probe.

IMPORTANT: Do the exchange of the wear and tear head at a well cleaned place, because dirt particles can cause a malfunction of the probe.

4.3 INSTALLATION OF WATER CONTROLS

4.3.1 WATER SUPPLY TO THE MIXER



4.3.2 WATER DISTRIBUTION

The number of nozzle positions is to be selected in such a way that the surface of the mixer is uniformly wetted through a ring line because this is the most efficient way to add water to the mixer. In some cases, it is possible to direct the nozzle jets onto the mixing tools and the probe holder in order to achieve a cleaning effect there and to avoid the formation of surface leakage currents. The size of the nozzles and the cross section of the line depend upon the size of the mixer. In principle, the valve should always be located below the nozzle in order to prevent continued flow after switching off the valve and inaccuracies in the mixing. Should this not be possible, the nozzle line is to be laid with a goose neck. In order to be able to set many desired spray angles, the nozzle is installed in a 90° elbow (or right angle) which is connected using a pipe socket to a second 90° elbow (or right angle). In turn, this is set into a second pipe socket welded into the feed line. To prevent continued flow after switching off, it is also possible to use nozzles which close automatically after the water pressure drops.

Advices for installing and starting up of the water volume recorder

1. Rinse the pipe properly before installing the water volume recorder.
2. The lane indication arrows on the counter cover have to correspond with the flow direction of the water.
3. The counters are foreseen for horizontally installation concerning the life time and measure exactness (counter upward).
4. The electrical wiring has to be done as our connection values say.
5. The counter has to be installed that way that no air cushions can form up, anyway. You can reach this best, if you install the counter at the deepest point of the pipe.
6. The counter has to be bled before installation. Therefore you open the valve slowly until a quite quantity of water is flown free.
7. If you use dirty water we recommend to install a mudguard before the counter.
8. Against vibrations or shocks we recommend to install the counter at an elastic base and between tubes.
9. When danger of frost comes up the counter has to be emptied resp. deinstalled.

5.0 ERROR SHOOTING

When our FL-MIKRO shows failures, please check first all LEDs on the back of the device. (Please see point "3.13 Arrangement of Cards and Device Fuses"). All 5 LEDs have to light up in perfect function.

Device can not be started again:

If the device can not be started although the main voltage is arriving at the main plug (on the back of the device), please check both fuses F1 and F2 (see point 3.13)

Varying concrete consistency:

Check that the microwave probe is not damaged and is in perfect function. Go forward as described in point "1.8 Probe Check".

The probe has to be cleaned optimally through the mixer shares. Material on the probe (e.g. because probe is too deep in the mixer bottom) or material remaining on the measure surface is causing measured value varyings.

(See point "5.0 PROBE INSTALLATION...").

Make sure that the dry mix time is long enough (approx. 20 sec.). While dry mix time and measure phase no components have to be dosed in the mixer (e.g. colour, additional goods, a.s.o.).

Make sure that the wet mix time is long enough (approx. 20 sec.) to guarantee a sufficient homogenising of the dosed water quantity and the material. The dry and wet mix times are depending to the mixer capacity, the adjustment of the mixer shares, the mixer filling and the material. The mix times can perhaps extent.

Check perfect function of the water counter. The small displaying wheels of the counter do not have to turn jerky. The water quantity which is shown while dosing has to correspond with the FL-MIKRO's calculated addition water (not including any possible measure check of the valve).

5.1 ERROR ANNOUNCEMENTS OF THE FL-MIKRO AND POSSIBLE CAUSES

Certain errors are determined by the FL-MIKRO itself. The program is stopped at the particular stop, the alarm output is set and an acoustic signal is been giving. The mixer staff can return back to the "START MENUE" when touching the "CONTINUE"-key.

The FL-MIKRO is able to show the following failure announcements:

ERROR 1

VARYING MEASURED VALUES

is shown, if the mixing cycle takes longer than the fixed information "TIME ERROR 1" in parameter 3, max. possible measure time (standard value = 50). "TIME ERROR 1" can be find in "SYSTEM DATA".

Possible causes:

- Microwave probe or probe cable defective (Steps for checking of probe and cable please find in point "1.8 CHECK PROBE").
- Mixing not homogenized enough.
Make sure that the dry mix time is long enough (ca. 20 sec.). No components have to be dosed in the mixer while dry mix time resp. measure phase (e.g. colour, addition goods, a.s.o.).
- In menu "SYSTEM DATA" the following parameters have been entered too low: "MAX. DIFFERENCE" (standard value = 0,03) or "TIME ERROR 1" (standard value = 50).
- In menu "SYSTEM DATA" the following parameters have been entered too high: "NO OF MEASURE HOMOG." (standard value = 10) or "MEASURE OF AVERAGE VALUE" (standard value = 5).
- Computercard FLBUC is defective.

ERROR 2

NO WATER

is shown, if there are no impulses coming to the water counter entry (clamp 17, clamp 18) approx. 10 sec. after the valve output has been set (while main dosing, pre water dosing, hand dosing). The delay time about 10 sec. is fixed and can not be varied. When failure announcement "NO WATER" the valve output is set back immediately.

Possible causes:

- Valve defective.
- No air pressure at the valve (if the used valve is a pneumatic one).
- Water counter defective.
- Mudguard is blocked up.
- No water pressure.
- Outputcard FLAT defective.
- In- and outputcard FLOPTO is defective.

ERROR 3

VALVE OPEN

is shown, if the FL-MIKRO is getting impulses from the water counter in program steps where no water has to be dosed (e.g. while dry mix time).

Possible causes:

- Valve is not closing anymore.
- Water measure check after is getting higher.
- Parameter "COUNTER IMPULSE ERROR" in "SYSTEMDATA" has been set too low (standard value = 15).
- The reed contact of the water counter is defective.

ERROR 4

NO MEASURED VALUE

is shown, if the measured Is-Wat/Cem-Ratio is lower than the parameter "NO MEASURED VALUE" in "SYSTEM DATA".

Possible Reasons:

Microwave probe or probe cable are defective (Measures for checking of probe and cable please find in point „1.8 CHECK PROBE“). The parameter "NO MEASURED VALUE" in „SYSTEM DATA" has been set too high (standard value = 0,01) . Power supply 24 V of the probe broken down. Check here the voltage at clamps 52 (+24V) and 53 (GND 24 V). If there is no voltage measurable, the FLNT 24 V card is defective and has to be changed (see **page 3.13**).

ERROR 5

TOO WET (last measured IS-Wat/Cem-value)

Is shown, if the measured IS-Wat/Cem-Value is higher than the former set Set-Wat/Cem-Value (in program data or via serial interface).

Possible Reasons:

The mixing goods are moister than the former set Set-Wat/Cem-Value.

The microwave probe or the probe cable are defective (Measures for checking of probe and cable you can find at point „1.8 CHECK PROBE“).

Computer card FLBUC is defective.

ERROR 6

CEMENT?

Is shown, if the cement weight is not present which is necessary for calculating the water quantity.

Possible Reasons:

- In "PROGRAM DATA" no or a lower cement weight (< 1kg) as set is recognized during the present choosed program by devices with contact actuation resp. "Hand"-Mode ("PROGRAM MODE" = 0, 1, 2, 3 or 4.
- No cement weight or a lower cement weight (< 1kg) is transmitted by devices with 0-10 V cement weight reading ("CEMENT MODE" = 1).
- No cement weight or the whole cement weight was readed again with grasping of the correct value by devices with 0-10 V cement weight reading and residue water correction ("CEMENT MODE" = 2).
- No cement weight was transmitted by devices which are equipped with a serial interface and which are receiving the cement weight via serial data exchange from the control ("PROGRAM MODE" = 6,7,8,9,...).

ERROR 7

CONCRETE TOO WET

(Only possible, if your device has activated "MEASURE CHECK MODE" = 1).

"ERROR 7 CONCRETE TOO WET" is monitored if the determined moisture value of the measure check toppes the limited value in "MEASURE CHECK TOO WET" (program data).

Possible Causes:

- The end moisture of the mixing is too high (valve running after too high).
- The parameter "MEASURE CHECK TOO WET" in "PROGRAM DATA" has been entered too low.
- The parameter "SCALE OFFSET MEASURE CHECK" has been entered too high in "PROGRAM DATA".

Informations to the parameters and to the measure check you will find in point

"2.10 MEASURE CHECK".

ERROR 8

DATA TRANSFER

(Only possible, if your FL-MIKRO is communicating with the control via serial interface)

"**ERROR 8 DATA TRANSFER**" is monitored, if the FL-MIKRO tries to send a telegram 5 times without success to the control (no reporting back of the control or r "NAK").

Possible Causes:

- Data transmission cable between FL-MIKRO and control is defective (Check that the serial interface plug at the back side of the FL-MIKRO and at your control are firmly fixed).
- False setting of the parameters "**PROGRAM MODE**" in menu "**OPERATION MODE**" or "**COM2 BAUDRATE**". The correct setting of these parameters is described in your "**FL-MIKRO DEVICE PASS**" at point 7.0.
- Defective interface connection in you control.
Defective card FL-BUC in the FL-MIKRO.

ERROR 9

PROBE DEFECTIVE

Appears, if there are unrealistic values at both probe channels.

You can quit this error message with using the "**CONTINUE**"-field. So it is possible to work in a reduced way.

Check the microwave probe as described in "**1.8.2 CHECK PROBE**":

This error message comes again after each using of the "**RESET**"-key resp. the "Die Fehlermeldung wird nach jeder Betätigung des "**RESET**"-Tasters bzw. des "**MAINS**"-switch.

ERROR 10

TOO MUCH WATER

(Only by devices which are equipped with a 0-10V-reading of the water scale impulse "**WATER SCALE MODE**" = 3 or which can read the water scale value via serial interface.)

If the predosed water quantity in the water scale toppes the water quantity to dose, the FL-MIKRO gives the error message "**TOO MUCH WATER**". The valve output will not be set.

Possible Causes:

- Too much has been weighted into the water scale.
- The inherent moisture of the additional goods is that high, the the water quantity of the scale is higher than the residue water quantity to dose.

ERROR 11

DOSING TOLERANCE TOPPED

Appears, if the difference between the actual measured IS-Wat/Cem-Ratio and the last measured IS-Wat/Cem-Ratio of this program is higher than the parameter "**DOSING TOLERANCE**" in "**SYSTEM DATA**".

Possible Causes:

- Heavily unstable inherent moisture of the additional goods.
- Parameters "**DOSING TOLERANCE**" in menu "**SYSTEM DATA**" have been entered too low.
- Micro wave probe is dirty or defective. Check the probe as described in "**1.8.2 CHECK PROBE**".
- If your FL-MIKRO has a temperature compensation, high temperature changand the program ends in the normal way.

After using the "**CONTINUE**"-field the monitored water quantity is dosed and the program ends in a normal way.

For final quit of the program and for return to the "**START MENU**" please press the "**RESET**"-key.

ERROR 12

TABLE

No Calibration Curve has been set in Program Data and here the present program.

(possible Calibration Graph No. 1 - 12)

After pressing the **CONTINUE**-field the standard graph 13 is automatically set and the program process is resumed.

5.2 CHECKING LIST FOR WATER DOSING PLANT

MICROWAVE MOISTUREPROBE

You have to check that the measuring probe is even with the mixer bottom and that the mixer share is cleaning the probe (rubber share, plastic share). Furthermore no moisture nests must stay on the probe through dropping water or similiar aggregates.

ELECTRICAL CONNECTIONS

The measure cables and the electrical connections of the measuring probe and the water volume recorder have to be in good condition and have to be connected in a shielded way to the FL-MIKRO device. The shielding has to be connected to the clamps PE in the FL-Mikro.

MAGNETIC VALVE

It has to be ascertained that the magnetic valve is good closing and does not have a measure check too high resp. no unregular measure check. Minimize the water pressure, if necessary.

WATER VOLUME RECORDER

You have to make sure that the wheels of the counter are turning in a steady way, this means not jerky.

During the water dosing the dosed water quantity should runs steady down in the display.

5.3 INTERFERENCE OF ISM-FREQUENCIES

radio frequency devices use particular ISM-Frequencies (Industrial Scientific and Medical), which are international prescribed. Our Microwave Moisture Probe, which counts as this type of device, is operated inside the frequency range from 433,05 to 434,79 MHz. Radio frequency ranges are utilized in many commonly known devices. An example of these devices are as follows.

Radio Alarm Systems	- Vehicle Opener
Mobile Transmitters	- Garage door Opener
Remote Controls	- Wireless Movement Detectors

On account to the huge number of ISM-Devices it can lead to mutual influences resp. interferences, if they are operated in direct neighbourhood. The radio signals might be received from other as the expected receiver. To avoid each kind of interferences, we recommend, that your other operating ISM-devices, which use the range from 433,05 – 434,79 MHz as well, not be used in immediate vicinity of our Microwave Moisture Probes resp. be laid out for other ISM-Frequencies. This goes especially for possible danger zones as for example cranes, roll-doors, buckle conveyor belts, e.g. In researches and tests, which had been done by us and outside institutes, have been found out, that the from us used frequency range from 433,05 to 434,79 MHz is the most advantageous to get reliable and accurate Moisture Measurement with our Microwave Moisture Probes.

Please feel free to contact us. We look forward to answering any questions you may have.

6.0 SERIAL INTERFACE RS 232 (OPTIONALLY)

6.1 PLUG CONNECTION

(At the FL-MIKRO: 25-pole DSUB female)

PIN-Nr.	
1	
2	Sended Data
3	Received Data
4	
5	
6	
7	GND

Please notify:

No data are accepted in the first 5 sec. from the serial interface after switching on the device resp. after touching the „RESET“-key. If the parameter "TEMP. COMP. MODE" is set to "2", telegram A can only be received after the temperature impulse (clamp 35).